

Construction Resources

RAINWATER TECHNICAL SHEET

Construction Resources Rainwater Harvesting System with standard Vortex filter

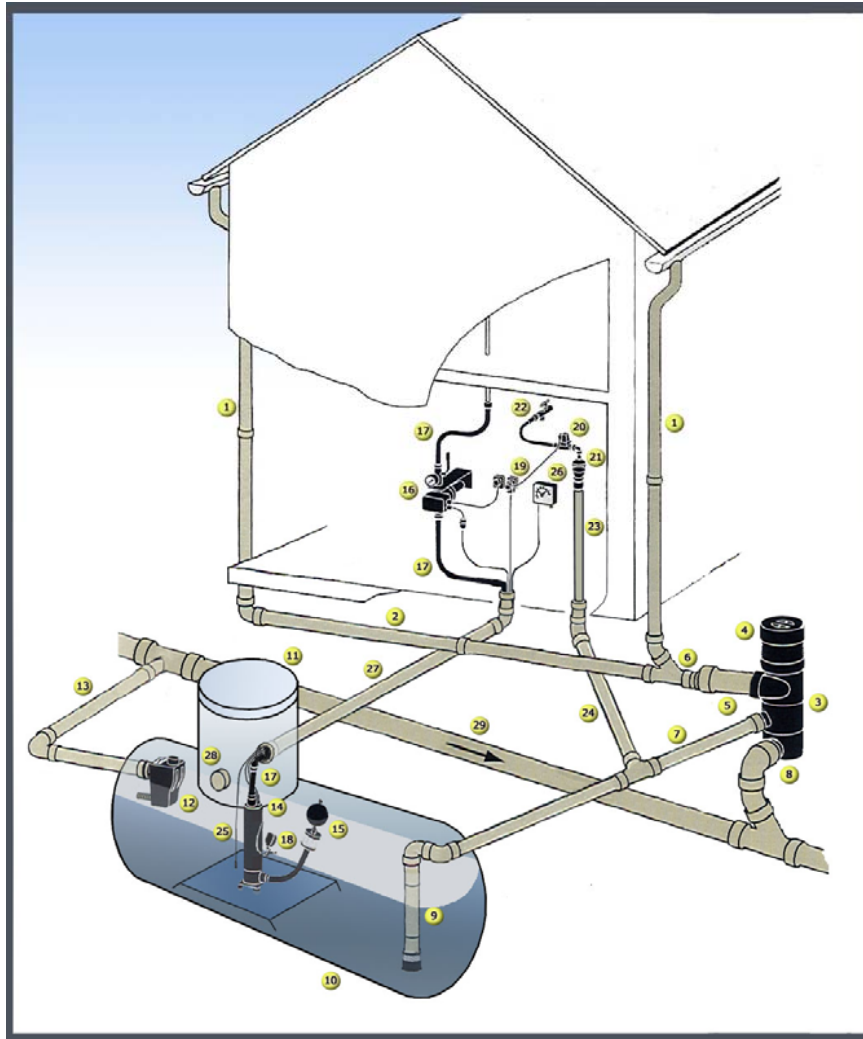

1. Rainwater down pipe
2. Surface water drain (110mm)
3. Standard Vortex underground filter
4. Vortex extension piece and lid
5. 500mm length of 160mm pipe to slow down flow of rainwater
6. 160-110mm reducer
7. Filtered rainwater (110mm)
8. Connection to drain for first flush and excess rainwater (160mm)
9. Smoothing inlet
10. Rainwater storage tank
11. Lockable access to tank
12. Overflow trap (anti-rodent or anti rodent and anti surcharge)
13. Overflow connection to drain (110mm)
14. Multigo pressure pump
15. Floating filter
16. Pump controller
17. Reinforced pressure hose
18. Float valve to control mains back up
19. Float valve switch connection
20. Mains back up solenoid
21. Tundish to provide a type AA air gap
22. Isolating valve for automatic mains back up
23. 50mm pipe
24. 110mm mains back up connection
25. Hydrostatic level sensor
26. Rainwater level display gauge
27. 110mm ducting for electrical and hose connections to tank
28. 110mm connection for venting of tank if required by Building Control. Cap off if not required.
29. Main drainage run (160mm minimum)

This diagram shows the Construction Resources Rainwater Harvesting System using the standard Vortex filter, Multigo pressure pump and automatic mains back up controlled by a float switch.

How the system works

All rainfall from the roof is channelled via the Vortex underground filter (3). The filtered rainwater goes to the rainwater tank. The smoothing inlet (9) prevents the fine sediment at the base of the tank being stirred up. The first flush of rainwater, leaves, and some of the rainwater during torrential downpours pass directly through the filter to the main drainage run.

The integrity of the stored rainwater is maintained by a trapped overflow (12). If the overflow is connected to the main drains then chose an anti rodent trap. If the drains are prone to surcharging specify an anti rodent and anti surcharge trap. In this case the main drain run must also be protected so that no foul water can enter the rainwater tank via the Vortex.

The rainwater storage tank is sized for every individual system. The tank is grp or concrete depending on site conditions and customer preference. Part H2 of the Building Regulations 2000 states the tank must have a lockable lid and be vented. The tank has a 110mm connection for venting (28).

The Multigo high pressure pump (14) is installed inside the rainwater storage tank. The connection between the pump and the pump controller (housed in the building) is in 1" reinforced pressure hose. This is run in 110 mm ducting. Also run in the ducting is the electrical supply to the pump and the float switch, and the hydrostatic level sensor (25) that monitors the amount of stored rainwater. The pressure hose should be a minimum of 500 mm below ground level to protect against freezing. The pump controller (16) protects the pump from dry running.

The float switch (18) in the rainwater storage tank (shown here connected to the pump body) controls a solenoid valve to allow a small amount of mains back up into the tank when the level of the stored rainwater is low. This has a type AA air gap incorporated (21) to conform to the current Water Regulations to prevent any possibility of back siphonage into the mains. The mains back connects into the filtered water run between the Vortex and the rainwater storage tank (24).

Factors to consider when designing the drainage layout

- Position of rainwater storage tank
- Surchage protection of main drainage run
- Surface water from roof only into rainwater storage tank. Any paved areas must run direct to drain
- Vortex must connect to main drainage run
- Overflow from rainwater storage tank must connect to main drainage run
- Filtered water from Vortex run to rainwater storage tank
- Invert level drop across the Vortex
- Mains back up pipe run and connection
- 110 mm ducting for the electrical connections and pressure hose

Construction Resources can offer a design service. Please call for more details.

This sheet was issued in June 2003 and may be superceded by later editions.